

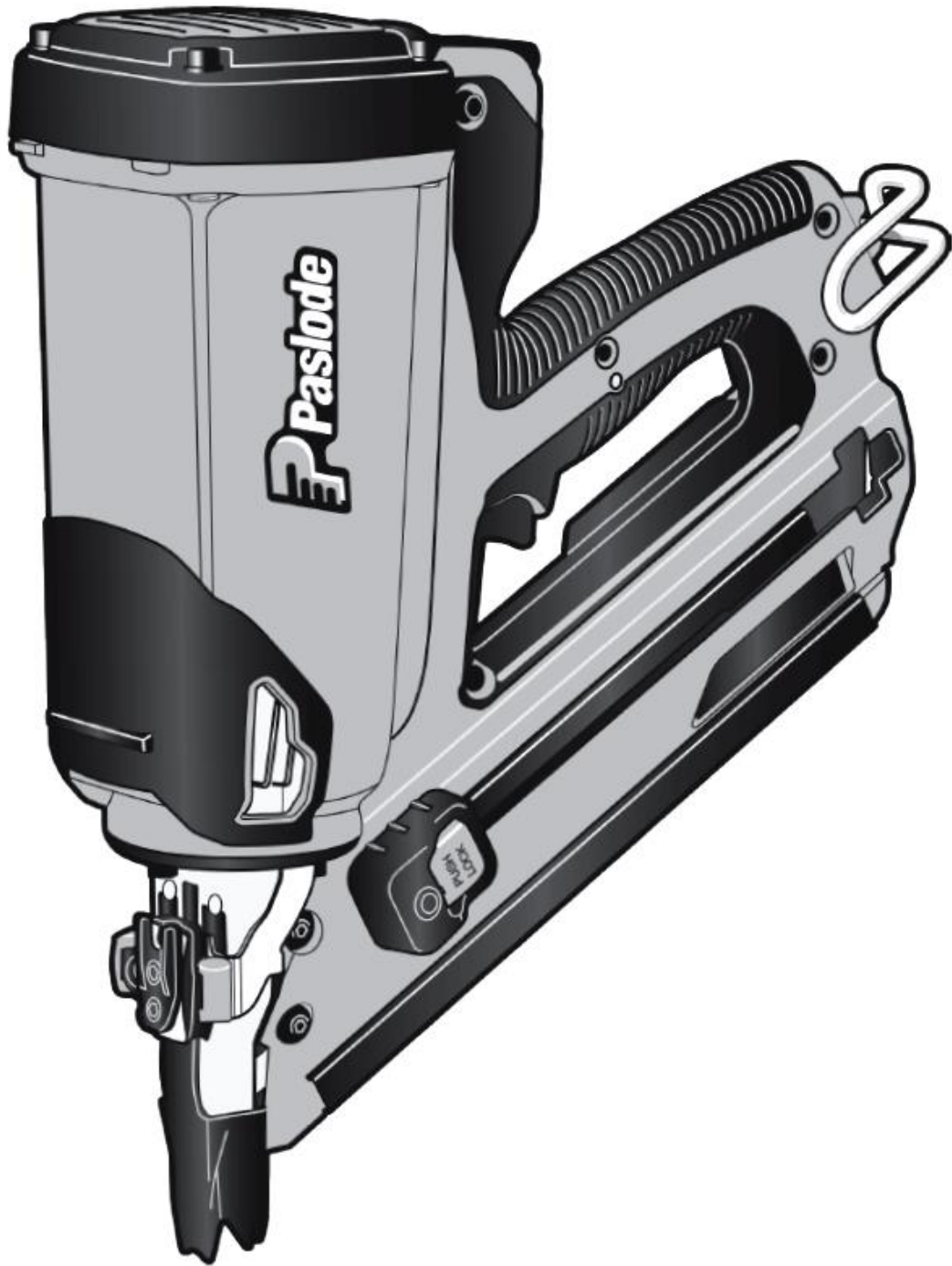

**IMPULSE
FRAMEMASTER Li
B20580 POWERVENT**



ILLUSTRATED PARTS LIST



FrameMaster Li Powervent (MK6) B20580

Torque Values (in/lb)			
Item	Torque	Item	Torque
1	55-60	40	55-60
4	20-25	43	55-60
7	30-35	54	55-60
10	20-25	56	30-35
11	16-18	58	6-8
16	16-18	61	35-40
18	8-10	73	130-140
20	45-50	78	6-8
23	20-25	86	18-20
40	30-35	91	18-20

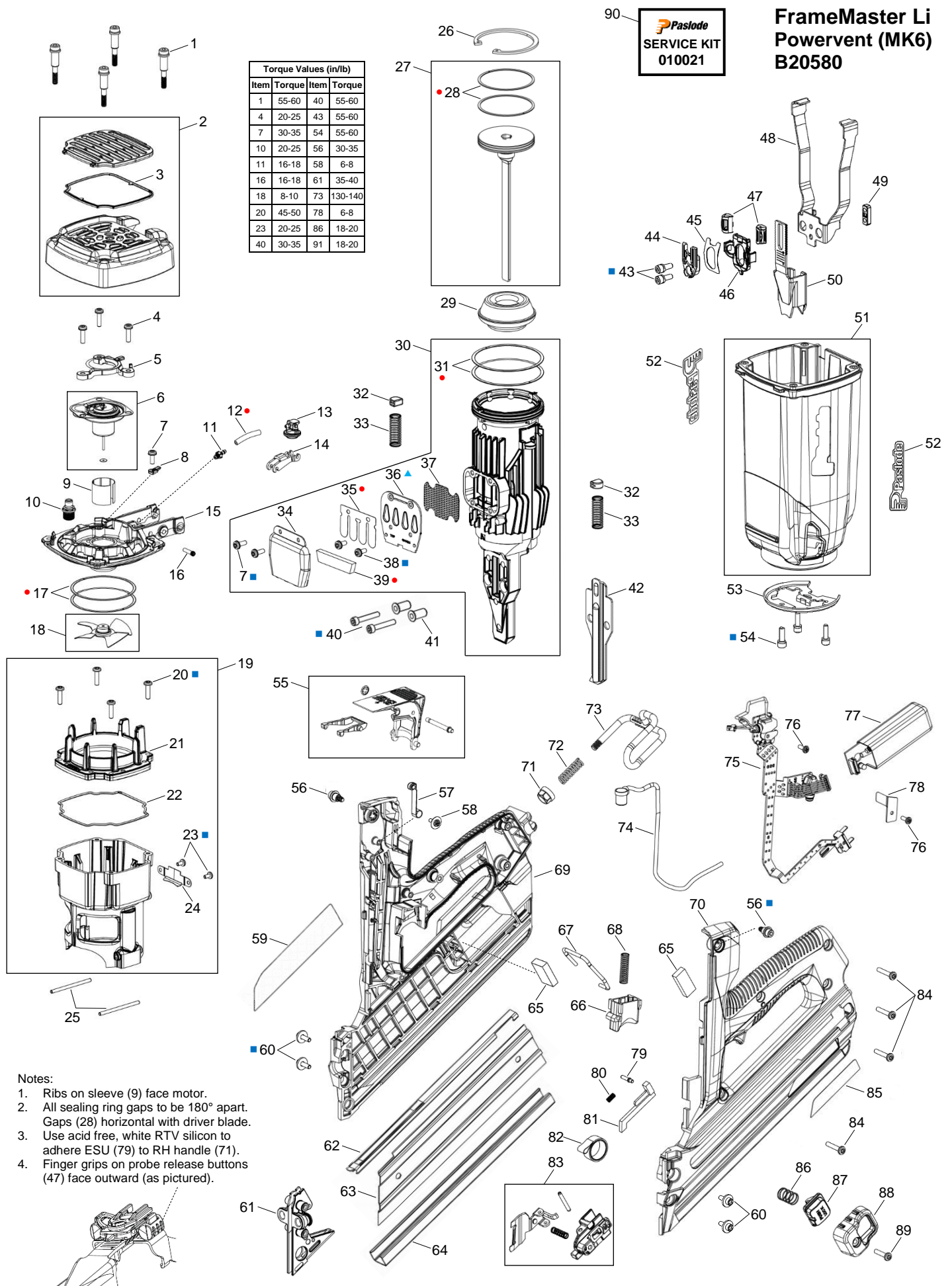

- Notes:
1. Ribs on sleeve (9) face motor.
 2. All sealing ring gaps to be 180° apart. Gaps (28) horizontal with driver blade.
 3. Use acid free, white RTV silicon to adhere ESU (79) to RH handle (71).
 4. Finger grips on probe release buttons (47) face outward (as pictured).

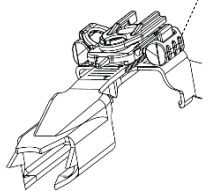

- Service Kit Item
- Loctite® 242
- ▲ Permatex® Blue 81724

All parts sold as single items unless described as a set etc., or forms part of an assembly (multiple items defined within a box). ie. A part with no item number is only available in an assembly.

PARTS LEGEND

PASLODE IM FRAMEMASTER Li POWERVENT (MK6)

B20580

1	901063	4	Screw, 10-24 x 1-1/2	46	902619	1	Release, Probe
2	906310	1	Cap & Grill Assembly	47	902620	2	Button, Probe Release
* 3	900315	1	Filter	48	901249	1	Yoke
4	900902	3	Screw TF SEMS 8-32 x 5/8	49	401380	1	Tie Bar
5	902637	1	Limiter	50	902225	1	Probe
6	902644	1	Motor Assembly, Fan	51	906301	1	Housing
■ 7	900596	3	Screw TX SEMS 8-32 x 7/16	52	906311	2	Label, Paslode Logo
8	404453	1	Clamp, Spark Wire Lead	53	902240	1	Ring, Sleeve-Housing Retainer
* 9	401356	1	Sleeve, Fan Motor	■ 54	900593	3	Screw SHC SEMS 10-32 x 1/2
10	900286	1	Spark Plug Assembly	55	902295	1	Fuel Door Assembly
11	904517	1	Fuel Barb	56	901222	2	Screw 10-32 x 1/2
● 12	904546	1	Fuel Tube	57	404448	1	Roller & Lever Assembly
13	902231	1	Fuel Block	58	900597	1	Screw TF SEMS 6-19 x 3/8
14	902211	1	Pivot Arm, Fuel Tube	** 59	906401	1	Label, Warning
15	902221	1	Cylinder Head	60	900594	4	Screw SHC SEMS 8-32 x 1/2
16	902213	1	Pin, Fuel Arm Pivot	61	906405	1	Shear Block
* ● 17	900935	2	Ring, Cylinder Head Seal	62	404436	1	Channel, Nail
18	403167	1	Fan Blade Assembly	63	902623	1	Cover Plate, Magazine
19	902551	1	Combustion Chamber Assy	64	905921	1	Channel, Magazine
■ 20	900969	4	Screw TX 8-32 x 5/8	65	904571	2	Pad, Foam
21	902222	1	Ring, Combustion Chamber	66	404435	1	Trigger
* 22	900481	1	Seal, Combustion Chamber	67	900269	1	Lock Bar, Chamber
■ 23	403987	2	Screw TF 6-32 x 1/4	68	404927	1	Spring, Trigger
* 24	404412	1	Wear Plate, Chamber Lockout	69	906303	1	Handle RH
25	404827	2	Pin	70	906302	1	Handle LH
26	401328	1	Ring, Retaining Circlip	■ 71	902227	1	Nut BH, Belt/Rafter Hook
* 27	404485	1	Driver & Piston Assembly	72	902238	1	Spring, Belt/Rafter Hook
* ● 28	401461	2	Ring, Piston	73	902237	1	Hook, Belt/Rafter Hook
* 29	905601	1	Bumper	74	900478	1	Spark Wire Lead Assembly
30	905623	1	Sleeve Assembly	75	905628	1	Circuit Board Assembly
* ● 31	900934	2	Ring, Sleeve Seal	76	404702	2	Screw, TF 6-32 x 3/8
32	404464	2	Stop, Rubber	77	906312	1	Electronic Spark Unit (ESU)
33	404411	2	Spring	78	900231	1	Retainer, Spark Wire Lead
34	404423	1	Cover, Muffler	79	403986	1	Pin, Negator
● 35	404424	1	Reed Valve	80	404457	1	Spring, Lockout Bar
▲ 36	404425	1	Reed Plate	81	404451	1	Lockout Bar, Follower
37	404426	1	Baffle, Exhaust	82	900520	1	Spring Assembly, Negator
■ 38	900595	2	Screw TX SEMS 8-32 x 3/8	83	906335	1	Follower Assembly
● 39	404422	1	Muffler	84	900453	4	Screw TF Torx 8-16 x 7/8
■ 40	403816	2	Screw SHC 10-24 x 1-1/8	85	906403	1	Label, Data Plate
41	404445	2	Bush, Shear Block	86	906336	1	Spring, Follower Button
* 42	902249	1	Wear Plate	87	906331	1	Button, Follower
■ 43	900592	2	Screw SHC SEMS 10-32 x 1/2	88	906332	1	Guide, Follower
44	901241	1	Stop, Probe Adjustment	→ 89	906322	1	Screw TF 8-16 x 3/4
45	901238	1	Spring, Leaf	90	010021	AR	Service Kit

* Normal Wear Items

** Ensure Warning Label is affixed and legible

● Included in Service Kit

■ Apply Loctite® 242 (Blue)

▲ Permatex® Ultra-Blue Gasket Sealant 81724

→ New Change

AR As Required

Remove battery, fuel & brads before commencing service.

Use eye and ear protection when operating/testing tools.

Use eye protection when cleaning tools.

Use degreaser in a well ventilated area.



WARNING: All parts must be periodically inspected and replaced if worn or damaged. Failure to comply can affect the tool's operation and present a safety hazard.

ACCESSORIES

Battery



Part No. B20543A

Battery Charger system (Australia/New Zealand)

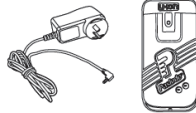

Battery Charger Kit (Shown)
Transformer
Charger Base

Part No. B20543B
Part No. B20543C
Part No. 902661

Carry Case

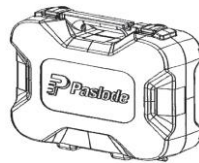

Part No. 905607
(RPLS 902609)

Replacement Latch
(Square Case 905607)

Part No. 219463

Replacement Latch
(Early Oval Case 902609)

Part No. 219233

Carry Bag

Paslode Pair Nylon (AU Only)



Part No. D80050A

No Mar Probe Assembly

Rubber tipped Probe to
eliminate marring work surface

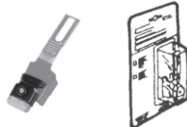

Replacement Rubber Tip

Part No. B20544G

Part No. 403369

5/32" Hex Key

For servicing and clearing jams.



Part No. 401331

T7 Torx Key

For Fan grub screw



Commercially
available

Paslode Impulse Lubricating Oil

Specially formulated for use in
Paslode® Impulse tools.



Part No. B20544F

Impulse Tool Cleaner/Degreaser

Recommended cleaner for all
Paslode®



Part No. B20544L