

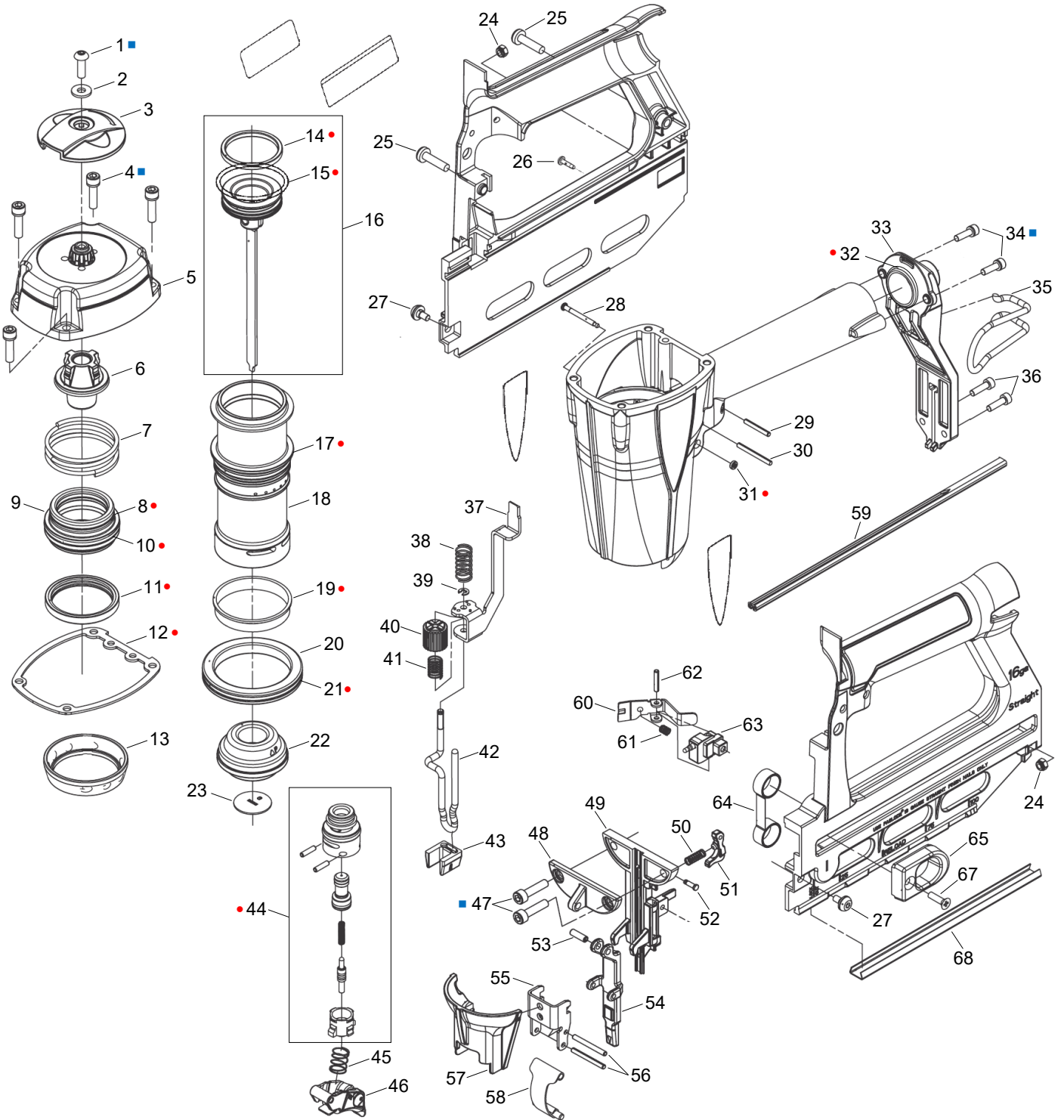

**PNEUMATIC T250S/F16
16G BRADDER
B20115 MK2 (AU)
B20116 (NZ)**



ILLUSTRATED PARTS LIST



• Service Kit Item
 ■ Loctite® 242

All parts sold as single items unless described as a set etc, or forms part of an assembly (multiple items defined within a box). ie. A part with no item number and is within a box, is only available with the assembly.

Individual parts with no item number have been discontinued.

PARTS LEGEND

T250SF16

AU B20115 MK2 / NZ B20116

■	1	501885	1	Screw SHC UH 1/4-20 X 1/2	35	501939	1	Hook, Belt
	2	501896	1	Washer, Flat	36	501938	1	Bolt SHC
	3	501899	1	Deflector, Air	37	501966	1	Lever, Safety
■	4	501901	1	Screw SHC	38	501967	1	Spring, Safety
	5	501902	1	Cap	39	501968	1	E-Ring
	6	501903	1	Stopper, Piston	40	501969	1	Wheel, Depth Adjustment
	7	501904	1	Spring, Main Valve	41	501387	1	Spring
*●	8	501905	1	O-Ring	42	501970	1	Probe
	9	501906	1	Piston, Main Valve	* 43	501971	1	No Mar Tip
*●	10	501907	1	O-Ring	*● 44	501988	1	Valve Assembly, Trigger
*●	11	501908	1	Seal, Cylinder	45	501932	1	Spring
*●	12	501909	1	Gasket	46	501933	1	Trigger Assembly
	13	501920	1	Collar	■ 47	501940	2	Screw SHC
*●	14	501910	1	Ring, Piston	48	501941	1	Plate, Nose Support
*●	15	501911	1	O-Ring	49	501942	1	Nose
*	16	501987	1	Driver & Piston Assy	50	501943	1	Spring, Lockout
*●	17	501913	1	O-Ring	51	501944	1	Lockout
	18	501914	1	Cylinder	52	501945	1	Pin, Lockout
*●	19	501915	1	Check Band	53	501946	1	Pin, Spiral
	20	501916	1	Bulkhead	54	501947	1	Plate, Nose
*●	21	501917	1	O-Ring	55	501949	1	Lever, Latch
*	22	501918	1	Bumper	56	501950	2	Pin, Roll
	23	501919	1	Seal, Driver Blade	57	501951	1	Cover, Latch
	24	501962	2	Nut, Lock	58	501948	1	Spring, Latch
	25	501965	2	Screw	59	501963	1	Channel, Nail
	26	501995	1	Screw	60	501954	1	Follower
	27	501961	2	Screw	61	501953	1	Spring, Follower
	28	501934	1	Pin, Trigger Pivot	62	501955	1	Pin, Roll
	29	501998	1	Pin, Spring	63	501952	1	Body, Follower
	30	501931	1	Pin, Spring	* 64	501956	1	Spring, Negator
*●	31	501089	1	Ring, Retainer	65	501958	1	Guide, Follower
*●	32	501936	1	O-Ring	66	501959	1	Screw PH
	33	501937	1	Cap, Air Inlet	67	501960	1	Cover, Magazine
■	34	501972	1	Screw SHC	→ 68	010020		AR Service Kit

* Normal Wear Items

** Ensure Warning Label is affixed and legible

● Included in Service Kit

■ Apply Loctite® 242 (Blue)

→ New Change

OP Optional

NP Non Procurable

AR As Required



Use eye protection when cleaning tools.

Use eye and ear protection when operating/testing tools.

Use degreaser in a well ventilated area

Use only approved Paslode Compressor Tool Oil PN F27625.

Never use mineral based oils.

Oil tool daily with 2 to 4 drops via air inlet connection.

Heavy usage will require more frequent oiling.

Operating air pressure at the tool inlet: 480-690 kpa (70-100 psi).

Never exceed the maximum stated air pressure.

Regularly check the regulator and pressure gauge operation.

A water/oil trap must be installed on the regulator outlet and drained regularly.

Never use bottled air or gases such as oxygen to operate the tool.



WARNING: All parts must be periodically inspected and replaced if worn or damaged.

Failure to comply can affect the tool's operation and present a safety hazard.

