

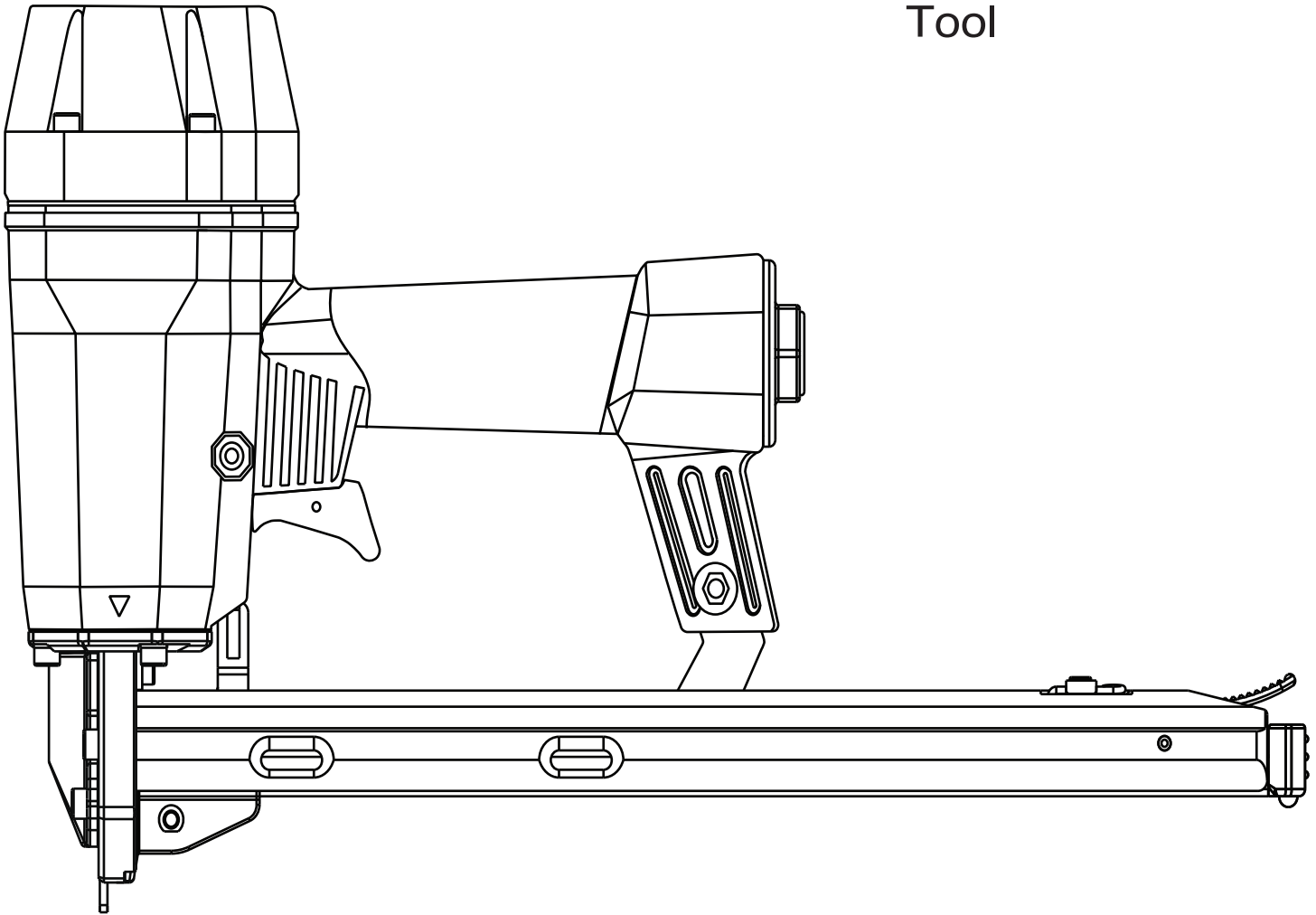

MODEL PCF 1000 SQ
Corrugated Fastener
Tool



IMPORTANT!

DO NOT DESTROY

It is the customer's responsibility to have all operators and service personnel read and understand this manual.

**OPERATING MANUAL AND
SCHEMATIC**

PARTS LEGEND

PCF 1000 SQ, A10569

1	502361	4	Screw	37	502718	1	Spring
2	1015483	8	Washer	* 38	501648	2	O-Ring
3	502362	1	Top Cap	* 39	502385	1	Trigger Valve
4	502363	1	Piston Stop	40	OMR.55.72.3	1	Bushing
5	502364	1	Spring	41	OMR.50.72.3	1	Trigger Valve Assy.
* 6	502365	2	O-Ring	42	501635	1	Screw
* 7	501621	1	O-Ring	43	511159	1	Nut
8	502366	1	Washer	44	502389	2	Screw
9	502367	1	Valve	45	502390	1	Support
10	502368	1	Valve Assy.	46	511160	1	Spacer
* 11	502369	1	O-Ring	47	511161	1	Pusher
12	502370	1	Piston	48	502393	1	Screw
* 13	502371	1	Driver Blade	49	502394	1	Spring
* 14	502372	1	Bumper	50	511162	1	Spacer Stop
* 15	501625	1	O-Ring	51	502396	1	Screw
16	502419	1	Driver Blade Seal	52	502397	1	Washer
17	502373	1	Noseplate	53	502398	1	Magazine
18	OMR.75.81.4	1	Lower WCE	54	502399	1	Nut
* 19	502428	1	Spring, WCE	55	502407	1	Latch
20	502375	2	Screw	56	502408	1	Screw
21	502376	1	WCE, Spring Cover	57	502409	1	Spring
■ 22	1015482	2	Screw	58	502410	1	Slider
■ 23	1015506	4	Screw	59	502411	1	Spring
24	502377	1	Sleeve Seal	60	502412	1	Roller
* 25	502378	1	O-Ring	61	502413	1	Pin
26	502379	1	Sleeve	62	502414	1	Inlet Cap
* 27	502380	1	O-Ring	* 63	502415	1	O-Ring
28	502381	1	Gasket	64	OMR.81.75.3	1	Trigger Assy.
29	502382	1	Housing	65	1015317	1	Screw
* 30	1015303	1	O-Ring	66	502417	1	Safety Guide
31	502383	1	Trigger Valve Housing	■ 67	501696	2	Screw
* 32	501860	1	O-Ring	68	502420	1	Plate
* 33	1015511	1	O-Ring	69	501140	1	Logo, Housing Left
* 34	501418	1	O-Ring	70	501141	1	Logo, Housing Right
35	502384	1	Valve Piston	71	502426	1	Warning Label
* 36	1015514	1	O-Ring	72	502427	1	Oil Daily Label
				73	OMR.91.21	1	Spring, Trigger

- * Denotes Normal Wear Items.
- ** Make sure Warning Label (502426) is properly affixed.
- Replace if necessary.
- Label available at no charge through the Service Parts Dept.
- ▲ Apply Loctite 242 (Blue)
- Apply Loctite (Green)
- Denotes New Change

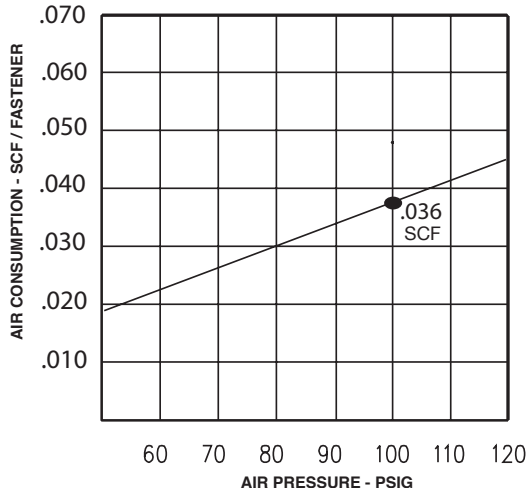

SAFETY INSTRUCTIONS

WEAR EYE AND HEARING PROTECTION



Always wear hearing protection and eye protection devices, including side shields when operating or working in the vicinity of a tool.

DO NOT EXCEED MAXIMUM RECOMMENDED AIR PRESSURE



Operate the tool using only the recommended air pressure. Do not exceed the maximum air pressure marked on the tool. Be sure the air pressure gauge is operating properly and check it at least twice a day.

Never use any bottled air or gases such as oxygen to operate the tool since they could cause the tool to explode.